

DUST CAT

Fully electric



DUST CAT

Fully electric

5 h 5.000 l 510 kW 300 kWh 90 m 27.600 Nm
Autonomy Full tank Performance max Battery capacity max Spray range turbine Instantaneous torque



Zero emission

All terrain

Supercharger 1000 V
Charging time approx. 2 hours

Tank with a capacity of 5000 liters
Dust binding device
EMI CONTROLS V22 Orca
Spraybar and high pressure pump

A fully electric tracked vehicle, designed for effective dust suppression in outdoor areas on challenging terrains such as quarries or swampy and steep lands.

Equipped with a 5,000-liter tank and a powerful EMI CONTROLS V22Orca-Turbine with a range of up to 90 meters, the DUST CAT ensures wide coverage in dust suppression. The vehicle also features special nozzles at the rear ends of its tracks for moistening and waterproofing the treated ground. With no additional emissions, the DUST CAT represents a sustainable and efficient solution for large outdoor surfaces, ensuring minimal environmental impact.

Dimensions

Overall length of vehicle
Overall height of vehicle
Overall width vehicle

5.600 mm
3.670 mm
3.800 mm

Weight

Vehicle with empty tank
Vehicle with full tank

11.523 kg
16.523 kg

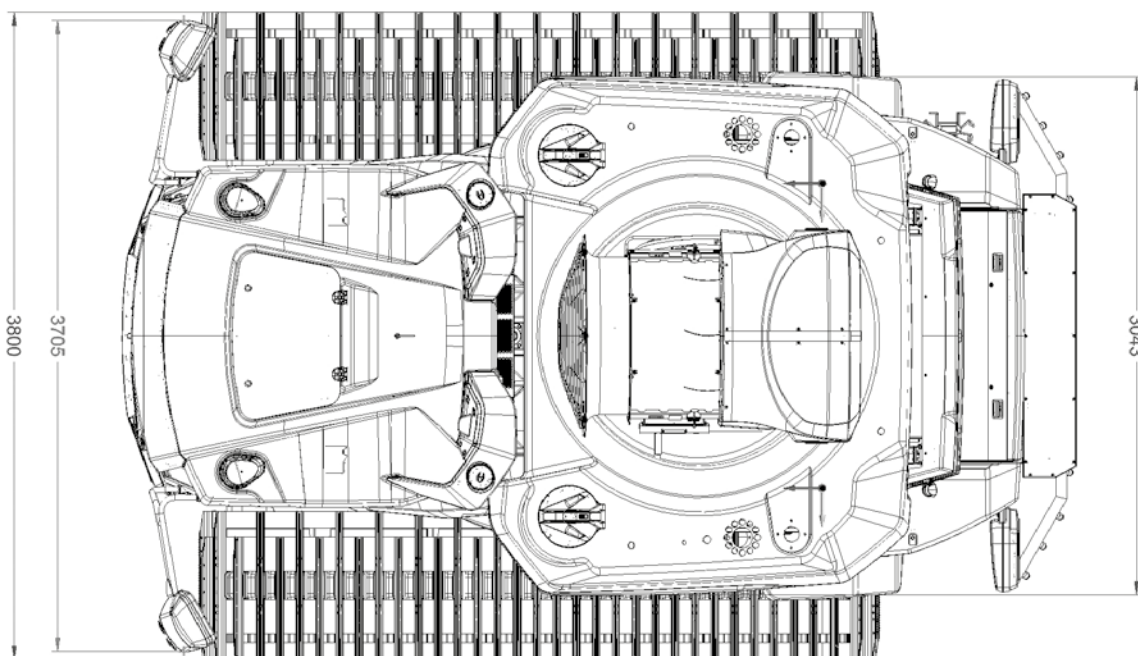
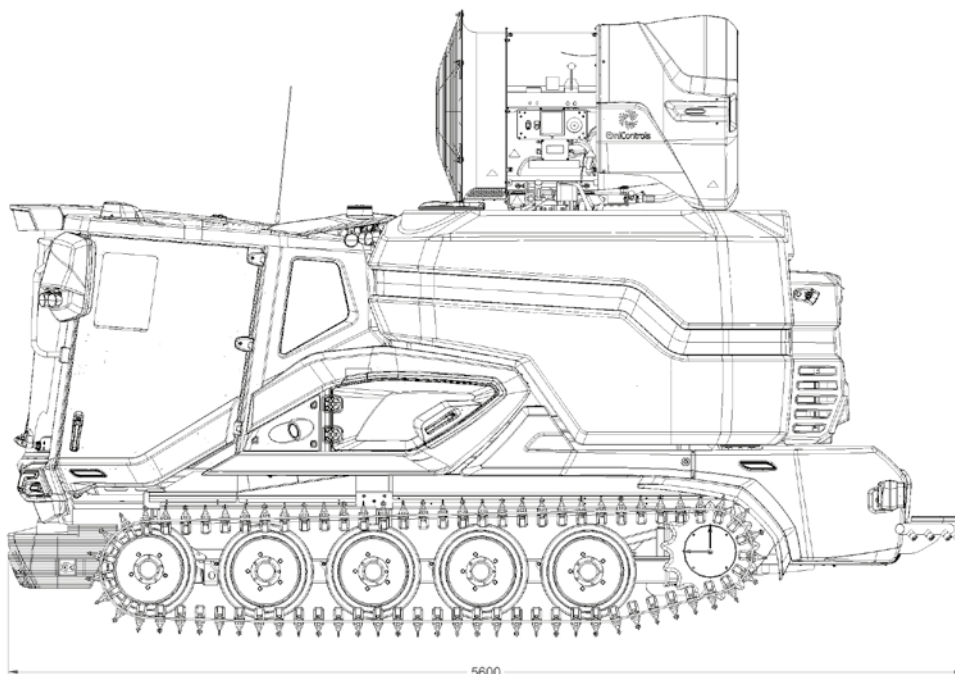
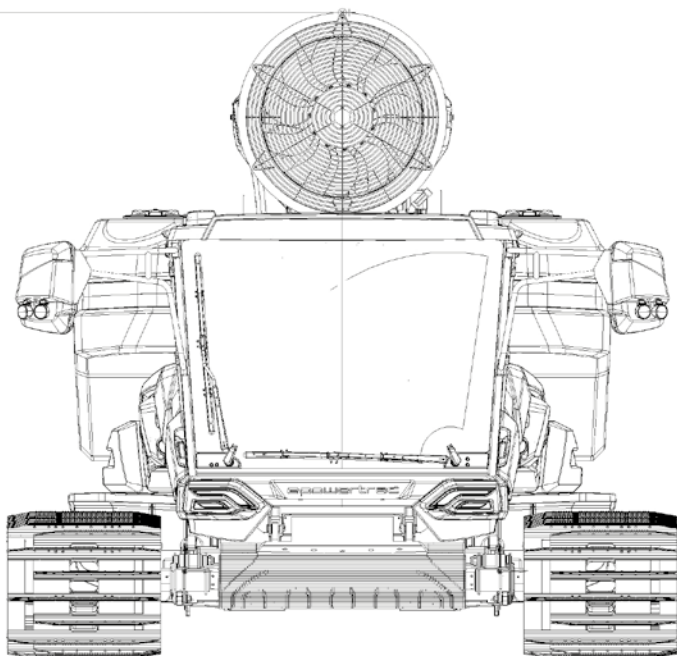



Dust binding device
EMI CONTROLS V22 Orca



Tilting
driver's cab



Spray bar and
high pressure pump



Electro-hydraulic
track tensioning

Illumination



Driving cabin

The driving cabin is designed to maximize comfort and ergonomics, integrating modern technologies that include advanced entertainment systems to enhance the driving experience.

- Comfort seats for driver and passenger
- Work screen: 12-inch touch display
- Armrest with multifunctional joystick
- Ergonomic arrangement of controls
- Joystick
- Speed limiter
- Tinted roof window
- Heated windows
- Full LED equipment with additional LED work headlights
- Heated mirrors, electrically adjustable
- Central locking
- Automatic climate control
- Software updates via remote access
- Radio: 9-inch touch display, FM, DAB Plus
- MP3 music and hands-free system via Bluetooth
- Apple CarPlay, Android Auto
- 4.1 sound system

The robustness and versatility of the design allow the DUST CAT to operate effectively on various types of terrain, ensuring high performance in all environmental conditions.

- Rearview camera
- Cruise control and speed limiter
- Onboard diagnostics
- Saving personalized driving settings
- Windshield wiper heating

unlimited power
zero emission
revolutionize your ride

