

SNOW CAT

Fully electric



SNOW CAT

Fully electric

5 h

Autonomy

510 kW

Performance max

300 kWh

Battery capacity max

150 kW

Charging capacity

27,600 Nm

Instantaneous torque



Zero emission



All terrain



Low maintenance



Remote support



Quick-change system for attachments



Supercharger 1000 V
Charging time approx. 2 hours

The SNOW CAT by xelom is a cutting-edge electric vehicle designed to tackle the challenges of snowy slopes safely and efficiently, offering a completely new driving experience. This vehicle ensures immediate and powerful operability thanks to its potent electric motors with a torque of 27,600 Nm, and it guarantees a smooth ride even in extreme conditions. The high-capacity 300 kWh battery ensures extended operational autonomy of up to 5 hours, allowing for long work sessions without the need for frequent recharges. The fast-charging system, supporting power up to 150 kW in direct current (DC), significantly reduces downtime, optimizing the use of electric energy and ensuring a quick return to action.

The strategy of reducing operating costs is a strong point of the SNOW CAT, with reduced maintenance and lower environmental impact, making xelom's SNOW CAT an ideal solution for operations in alpine environments, combining technological innovation, efficiency, and environmental respect in one cutting-edge vehicle.

Technical Data

Overall length of vehicle
4816 mm

Overall length of vehicle with mill and blade
8930 mm

Overall height of vehicle
2660 mm

Vehicle
7300 kg

Track chains 280 mm
900 kg

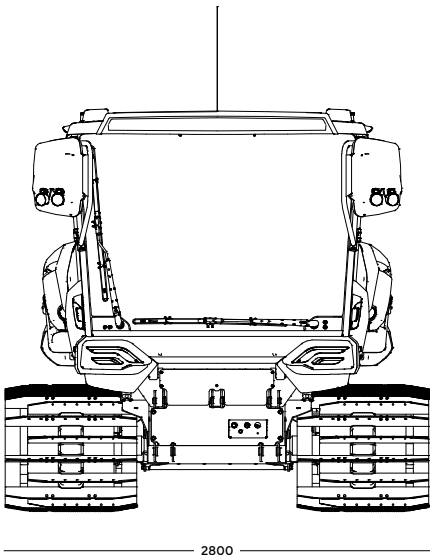

2800

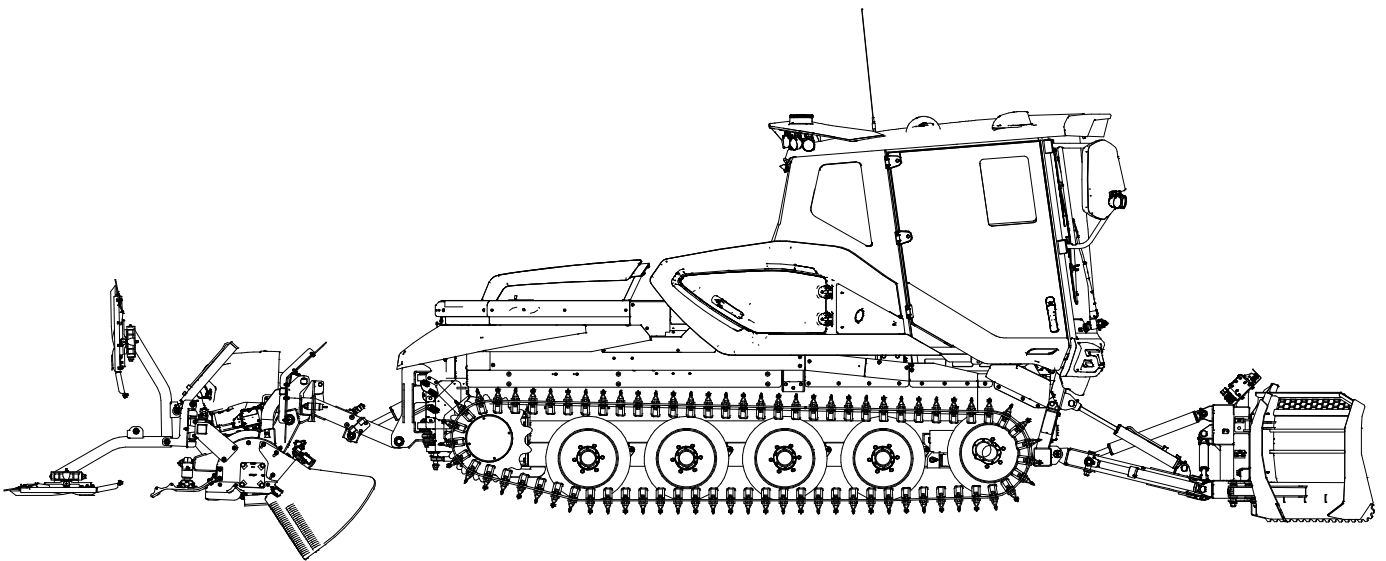

4816

8930

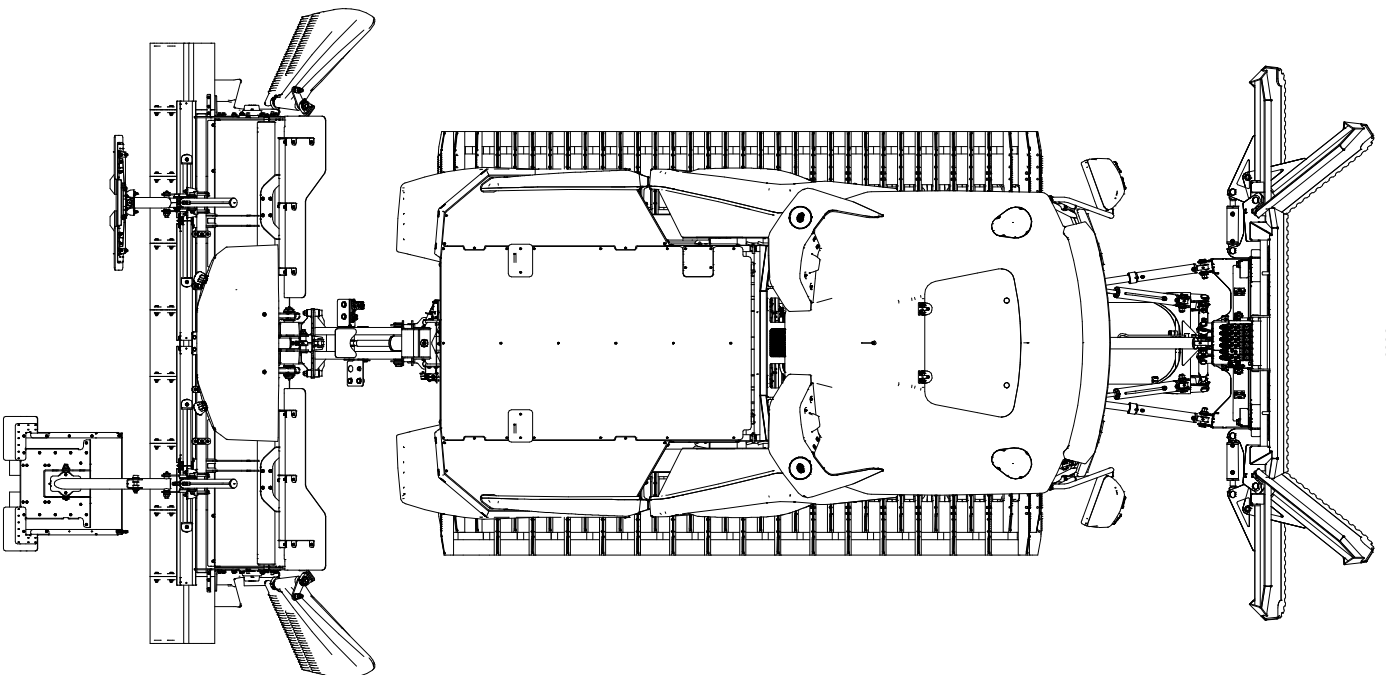

4430

2980

2930

3670

Width vehicle	Width tracks	Blade open	Blade closed	Tiller open	Tiller working width
2800 mm	870 mm	3670 mm	2930 mm	4430 mm	2980 mm
3200 mm	1070 mm	4070 mm	3250 mm	4830 mm	3380 mm
3500 mm	1220 mm	4430 mm	3550 mm	5230 mm	3780 mm

Tilting driver's cab



Hinged rear / loading area



Electro-hydraulic track tensioning



Lighting

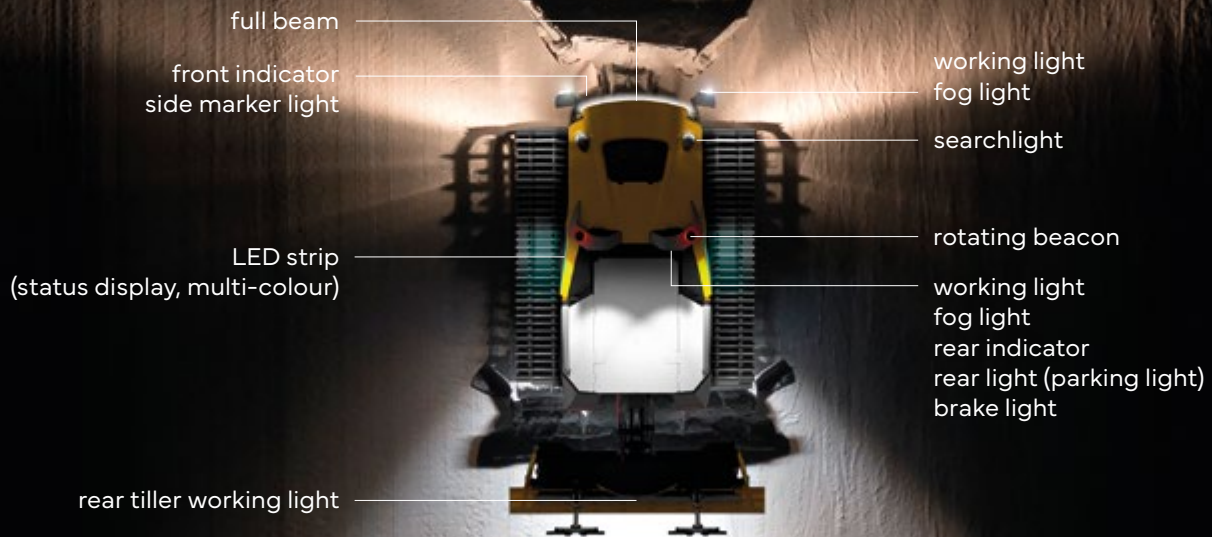

Driving cabin

The driving cabin is designed to maximize comfort and ergonomics, integrating modern technologies that include advanced entertainment systems to enhance the driving experience.

- Comfort seats for driver and passenger
- Work screen: 12-inch touch display
- Armrest with multifunctional joystick
- Ergonomic arrangement of controls
- Joystick
- Speed limiter
- Tinted roof window
- Heated windows
- Full LED equipment with additional LED work headlights
- Heated mirrors, electrically adjustable
- Central locking
- Automatic climate control
- Software updates via remote access
- Radio: 9-inch touch display, FM, DAB Plus
- MP3 music and hands-free system via Bluetooth
- Apple CarPlay, Android Auto
- 4.1 sound system

The robustness and versatility of the design allow the SNOW CAT to operate effectively on various types of terrain, ensuring high performance in all environmental conditions.

- Rearview camera
- Cruise control and speed limiter
- Onboard diagnostics
- Saving personalized driving settings
- Windshield wiper heating

unlimited power
zero emission
revolutionize your ride

