

DUST CRAWLER

Fully electric



DUST CRAWLER

Fully electric

5 h **5.000 l** 510 kW 300 kWh 90 m 27.600 Nm
 Autonomy Full tank Performance max Battery capacity max Spray range turbine Instantaneous torque



Dimensions

Overall length of vehicle 5.600 mm
 Overall height of vehicle 3.670 mm
 Overall width vehicle 3.800 mm

Weight

Vehicle with empty tank 11.523 kg
 Vehicle with full tank 16.523 kg

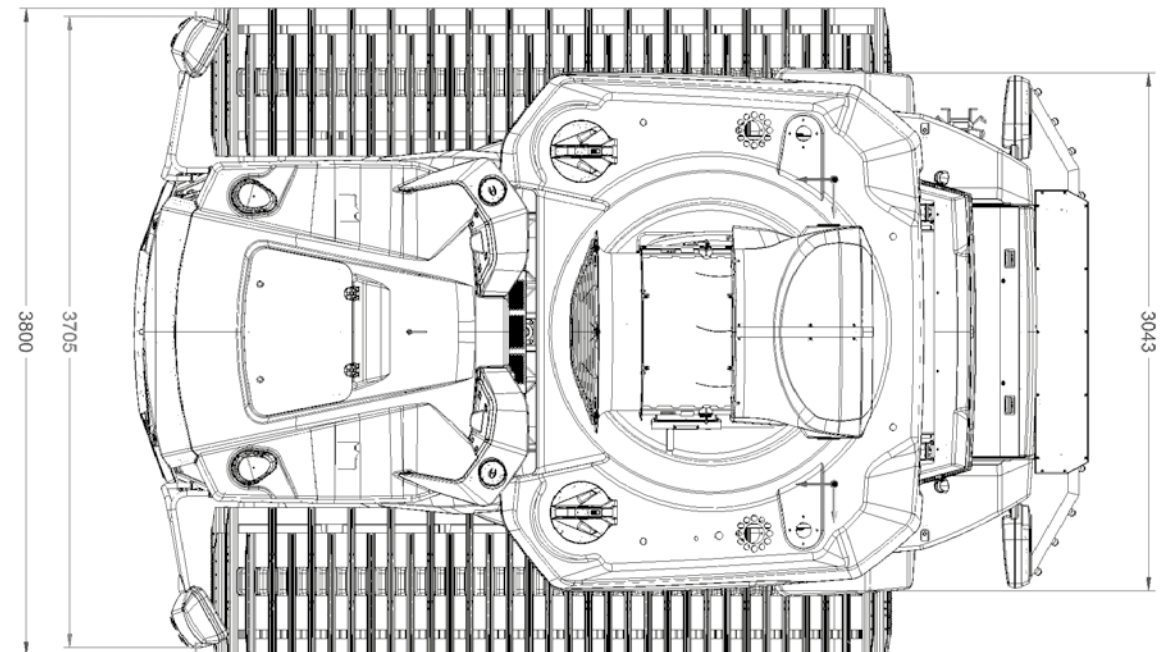
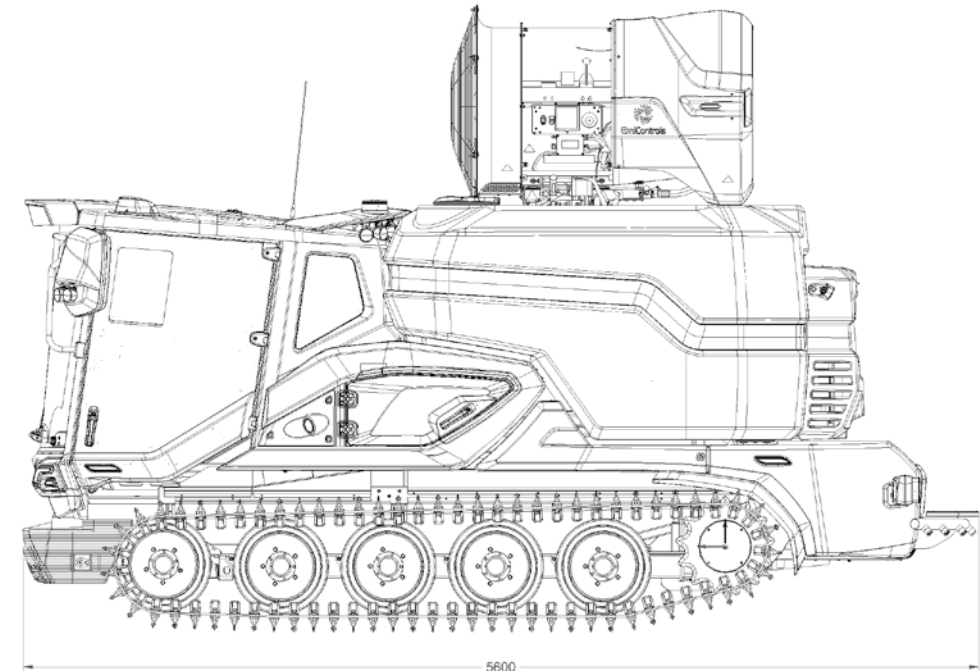
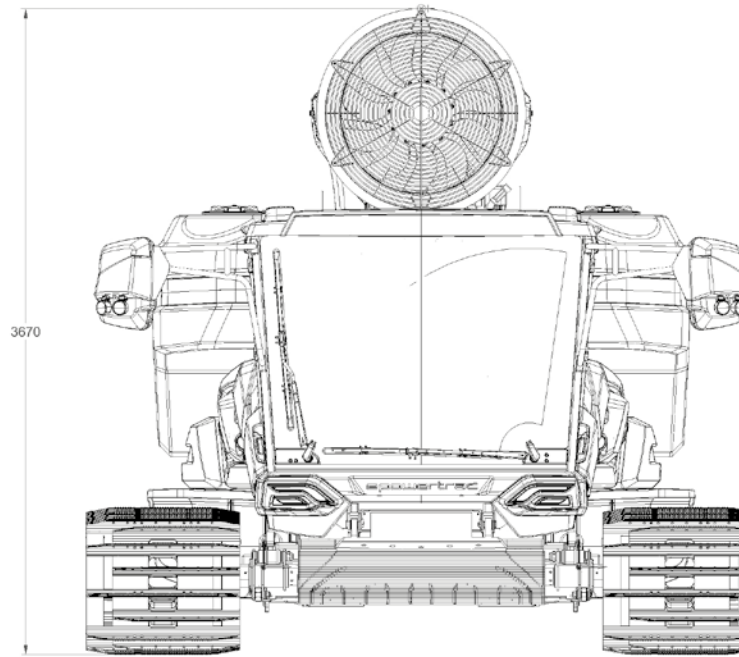

 Zero emission

 All terrain

 Supercharger 1000 V
 Charging time approx. 2 hours

 Tank with a capacity of 5000 liters
 Dust binding device
 EMI CONTROLS V22-Orca turbine
 Spraybar and high pressure pump

A fully electric tracked vehicle, designed for effective dust suppression in outdoor areas on challenging terrains such as quarries or swampy and steep lands.

Equipped with a 5,000-liter tank and a powerful EMI CONTROLS V22 Orca turbine with a range of up to 90 meters, the DUST CRAWLER ensures wide coverage in dust suppression. The vehicle also features special nozzles at the rear ends of its tracks for moistening and waterproofing the treated ground. With no additional emissions, the DUST CRAWLER represents a sustainable and efficient solution for large outdoor surfaces, ensuring minimal environmental impact.



Dust binding device
EMI CONTROLS V22 Orca

Tilting
driver's cab



Spray bar and
high pressure pump



Electro-hydraulic
track tensioning



Illumination



Driving cabin

The driving cabin is designed to maximize comfort and ergonomics, integrating modern technologies that include advanced entertainment systems to enhance the driving experience.

The robustness and versatility of the design allow the DUST CRAWLER to operate effectively on various types of terrain, ensuring high performance in all environmental conditions.

- Comfort seats for driver and passenger
- Work screen: 12-inch touch display
- Armrest with multifunctional joystick
- Ergonomic arrangement of controls
- Joystick
- Speed limiter
- Tinted roof window
- Heated windows
- Full LED equipment with additional LED work headlights
- Heated mirrors, electrically adjustable
- Central locking
- Automatic climate control
- Software updates via remote access
- Radio: 9-inch touch display, FM, DAB Plus
- MP3 music and hands-free system via Bluetooth
- Apple CarPlay, Android Auto
- 4.1 sound system

- Rearview camera
- Cruise control and speed limiter
- Onboard diagnostics
- Saving personalized driving settings
- Windshield wiper heating

unlimited power
zero emission
revolutionize your ride



TechnoAlpin Holding